

Spreading Technology

Introduction of topcut-bullmer spreading technology

German engineering is known in the world for its design combined with outstanding functional characteristics. The users benefit from high advantage in production, high efficiency and availability and low maintenance costs.

The wide range of fabrics and flat materials which are brought to bear differ extensively from each other. Topcut-bullmer therefore follows two objectives with his developments: First to built spreading machines, which can handle a wide spectrum of fabrics and second to enable them to cope with extreme needs.

In the area of material handling topcut-bullmer supports two ways. The fabric rolls are lead via a bar, which allows a very gentle winding. The bar can be powered respectively not driven. The alternative consists in a belt-driven cradle which provokes the perimeter of the roll. This technology offers the advantage to lead the roll without any attachment.

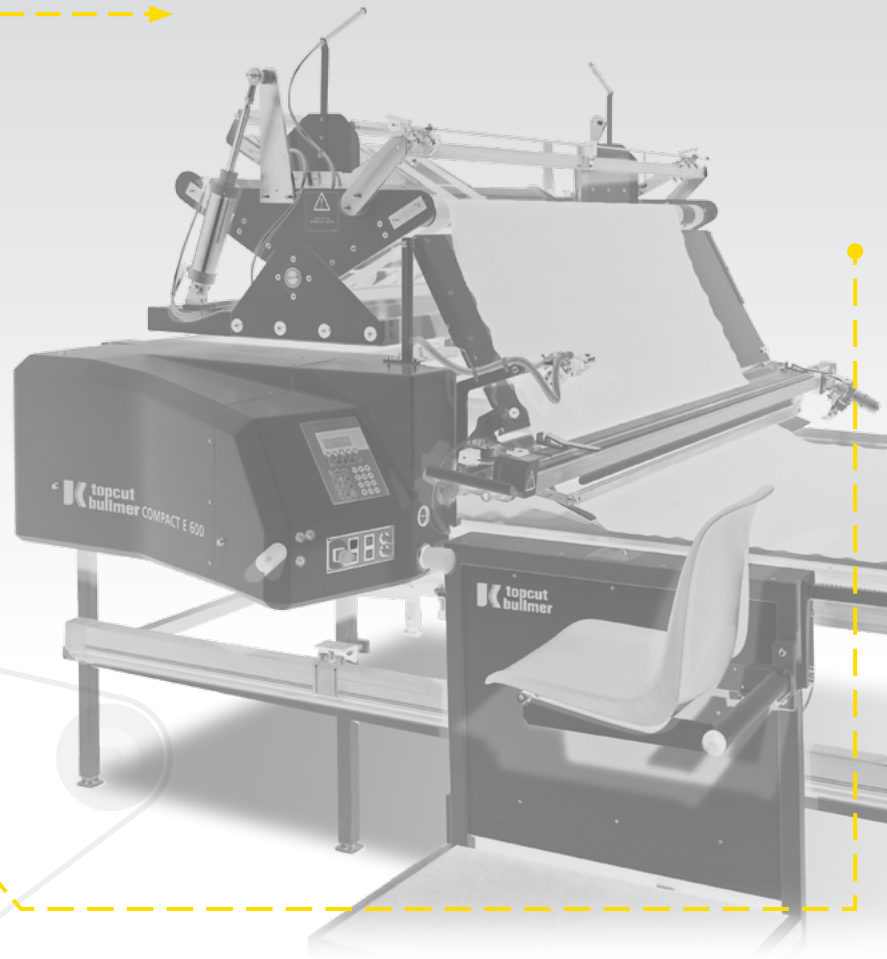

All standard versions of the machines can be upgraded by several options to meet the detailed needs of every plant. By this means each machine can be expanded even after installation.

Generic features and supplies

- Distortion-free, light sectional steel chassis.
- Four-wheel drive with „Vulkollan“ wheels.
- Stable lateral guidance with 4 lateral guide rollers at the angle bracket on the operator side.
- 3-phase traction drive with frequency control.
- Machine reversing speed can be adjusted separately.
- Automatic pre-centring of material beginning during threading.
- Electronic edge control, manually adjustable.
- Fault-cutting-off-mode with automatic synchronous material rewinding.
- Automatic return drive of spreader to the loading position at fabric end.
- Motor-driven lift for the cutting and zigzag unit, with automatic height adjustment at ply height.
- Control handle for continuous manual adjustment of the spreading speed.
- Power and air supply with cable drag chain.
- Encoder for measuring and controlling for drive and spreading length by means of a tooth belt at the table.
- Integrated, all-in-one controller opposite the operator side in externally blower housing.
- 4-fold emergency stop on both sides and at the front and back of the machine.
- CANBUCON 1 controller on free programmable basis, control panel with display, control in CAN-BUS technology.



(CANBUCON 1 controller)

Generic options and supplies

- One-way cutting device with continuous adjustable cutting speed.
- Zigzag device with tension compensation.
- Tubular knit supply.



- Attachment to layout piled tubular knit
- Static ply catcher.
- Movable ply catcher.



- Automatic level adjustment for step plies and hill-type plies.
- Sensor for fault brand detection (metal plates) with display indication and automatic machine stop.
- Blower ahead of ply-cutting in order to remove creases.

- Roller to smoothen fabric before cutting in order to remove creases.
- Fault detection handling system with touch screen (FDH system).
- Operator platform with emergency stop at the back of the machine.
- Seat for operator platform.
- Power supply with double contact carriage instead of cable drag chain (not possible when air supply is required).
- Slot for USB stick for importing external production data directly (in connection with CANBUCON 3).
- Link to spreading job optimisation programs (e.g. cost.assyst) via connection to an FTP server by online cable or wireless (W-LAN) (in connection with CANBUCON 3).
- Data transfer to fabric roll magazines (in connection with CANBUCON 3).
- Printer for recording material consumption (in connection with CANBUCON 3).
- Barcode scanner for importing article or material roll ID number (in connection with CANBUCON 3).
- CANBUCON 3: Compact controller with touch screen on a free programmable basis with integrated programming capability for all functions, parameters, job data, time sequences, safety functions and drive diagrams in CAN-BUS technology.



topcut-bullmer GmbH

Heutal 7, Industriegebiet
D-72537 Mehrstetten, Germany
Tel. +49 (0)7381 183-0, FAX +49 (0)7381 723
email: info@topcut-bullmer.com, www.topcut-bullmer.com